

# COMP-009

Submersible Compensator 2.0 L



## Highlights

- Designed for pressure compensation on hydraulic submersible systems.
- Compensation volume 2.0 litre.
- 3000 msw water depth rating.
- Corrosion resistant (AISI 316L stainless steel and synthetics).
- Includes 2 bar pressure relief valve and fill port.
- Two threaded connections (1x G3/8, 1x G1/4).
- Optionally provided with an analog level indicator.
- 4-pole male (standard or micro) circular underwater connector on level indicator version.

## Specifications

Mechanical		Environmental	
- Dry weight empty	11 kg	- Temperature range (in air)	-20...+50 °C
- Compensation volume	2 L	- Temperature range (in water)	-4...+50 °C
- Pressure completely full	±0.3 bar	- Rated water depth	3000 msw
- Pressure nearly empty	±0.15 bar		

Electrical (Optional level sensor)	
- Supply voltage	12...27 V DC
- Output	4...20 mA
- Accuracy	±10% FS

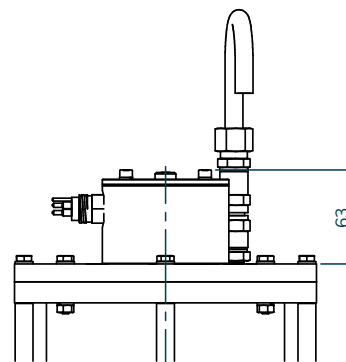
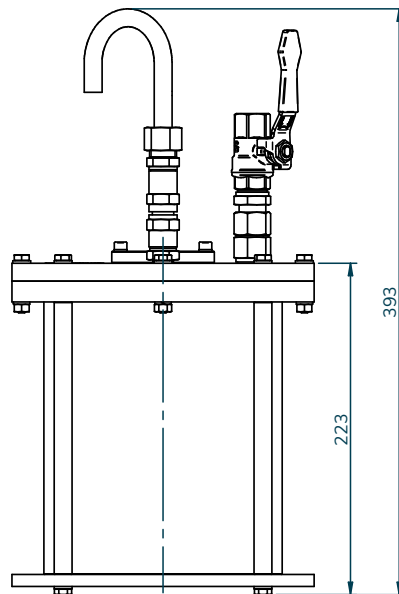
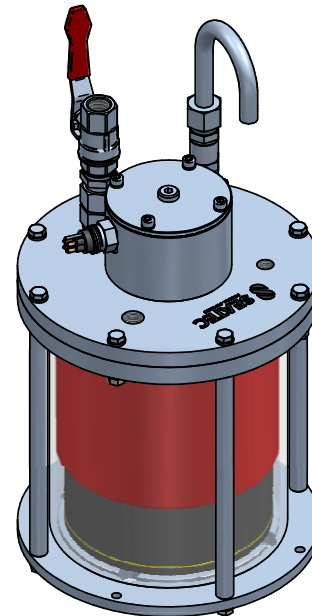
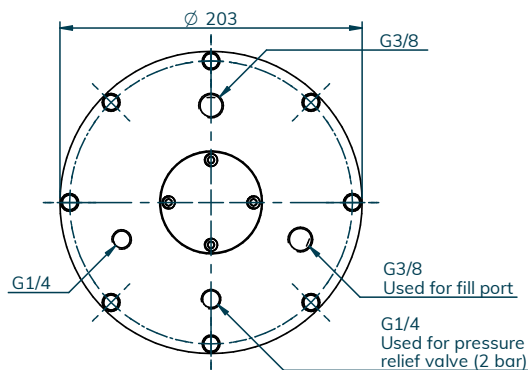

With level indicator

