

COMP-014

Submersible Compensator 15L

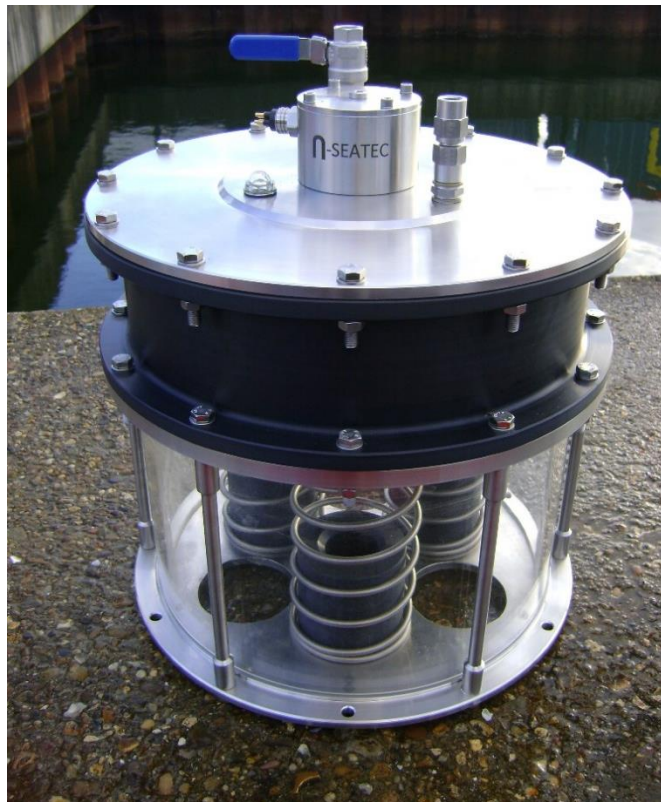

Highlights

- Designed for pressure compensation on hydraulic submersible systems.
- 3000 msw depth rating
- Corrosion resistant (AISI 316 L stainless steel and synthetics).
- Optionally provided with an analog level indicator.
- 4-pole male (standard or micro) circular underwater connector at level indicator version.
- Oil indicator on top flange.
- Hydraulic connection on a hose socket (1-off standard, 2-off on request).
- Compensation volume 15.0 litre.

Specifications

Mechanical		Environmental	
- Dry weight empty	30 kg	- Temperature range	0...+50 °C
- Compensation volume	15 l	- Rated water depth	3000 msw
- Pressure completely full	0.18 bar		
- Pressure when nearly empty	0.08 bar		

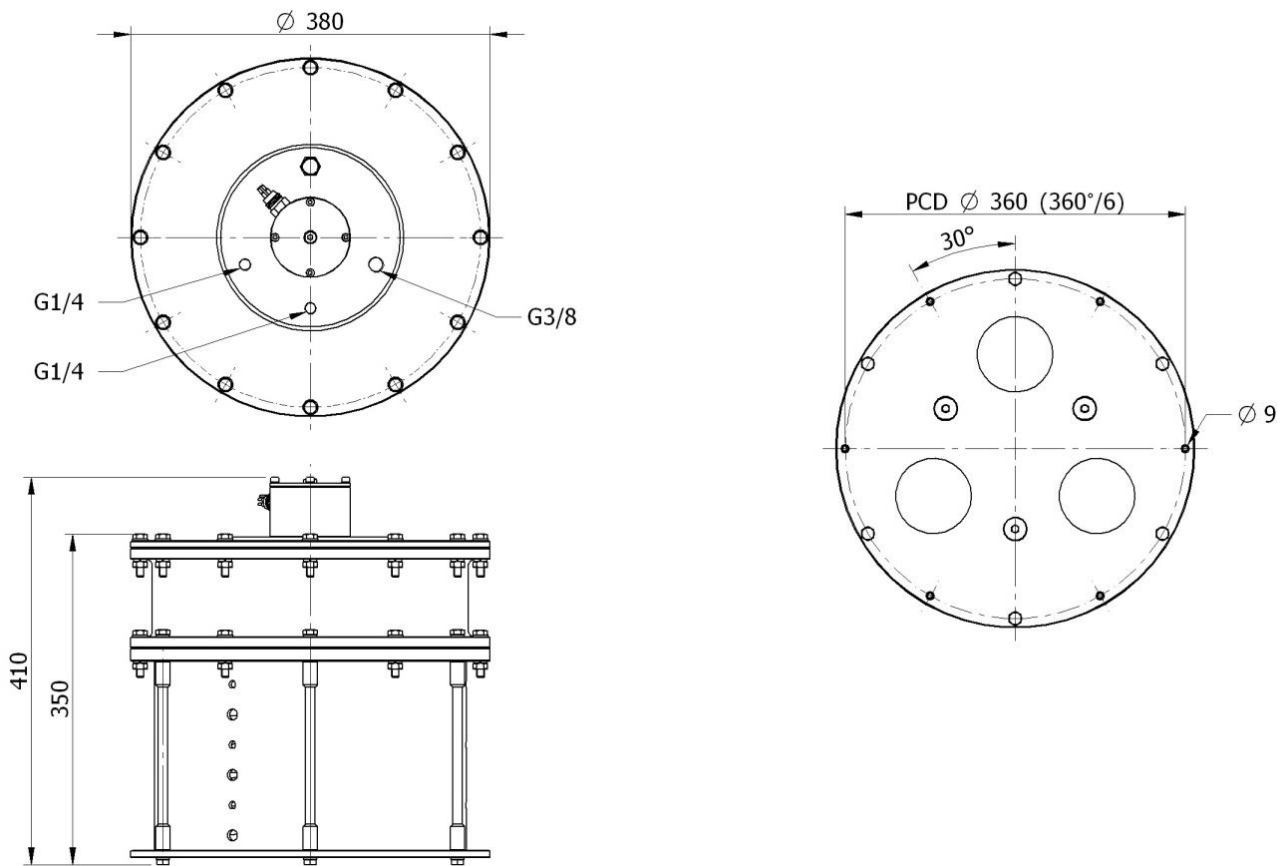

Electrical (Optional level sensor)	LEVEL version
- Supply voltage	12...27Vdc
- Output	4...20mA
- Accuracy	+/- 10% FS