

# COMP-009

Submersible Compensator 2.0L



## Highlights

- Designed for pressure compensation on hydraulic submersible systems.
- 3000 msw water depth rating.
- Corrosion resistant (AISI 316 L stainless steel and synthetics).
- Optionally provided with an analogue level indicator.
- 4-pole male (standard or micro) circular underwater connector at level indicator version.
- Oil indicator on top flange.
- Hydraulic connection on a hose socket (1-off standard, 2-off on request).
- Compensation volume 2.0 litre.

## Specifications

Mechanical		Environmental	
- Dry weight empty	11 kg	- Temperature range	0...50 °C
- Compensation volume	2 Liter	- Rated water depth	3000 msw
- Pressure completely full	+/- 0,2 bar*		
- Pressure nearly empty	+/- 0,1 bar*		

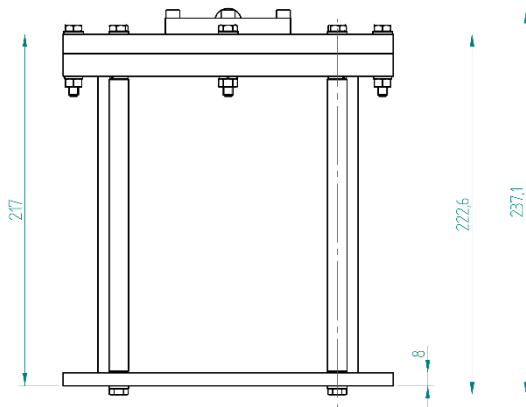
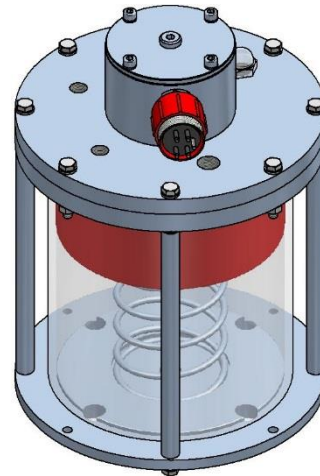
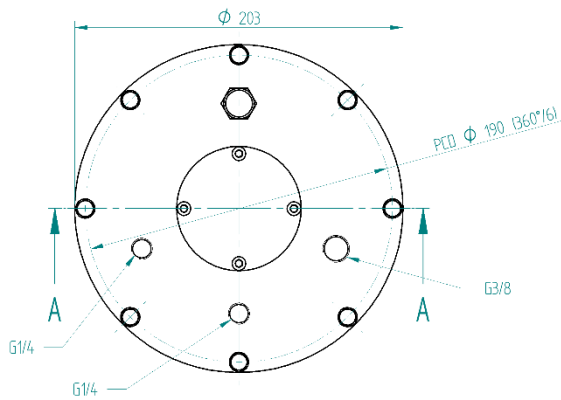

STANDARD VERSION

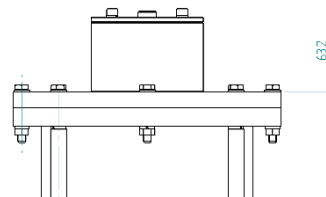

LEVEL VERSION

\*Option 1: 0,065 – 0,15bar, Option 2: 0,15 – 0,30bar

Electrical (Optional level sensor)	Current output	Voltage output
- Supply voltage	12...27Vdc	18...27Vdc
- Output	4...20mA	0,1...10Vdc
- Accuracy	+/- 10% FS	+/-10% FS