

LARS 15FT SWL 800kg



Product Highlights

- Designed to handle loads offshore.
- Dimensions based on 15Ft container footprint.
- Optional delivered including clump weight
- Clump stored in frame.

Information contained in this document is subject to change without prior notice

Specifications

Mechanical

- Tare weight (excl wires) 2.4 Ton
- SWL 0.8 Ton
- Dimensions LxWxH (mm) 4545x2440x2595mm

Operational position

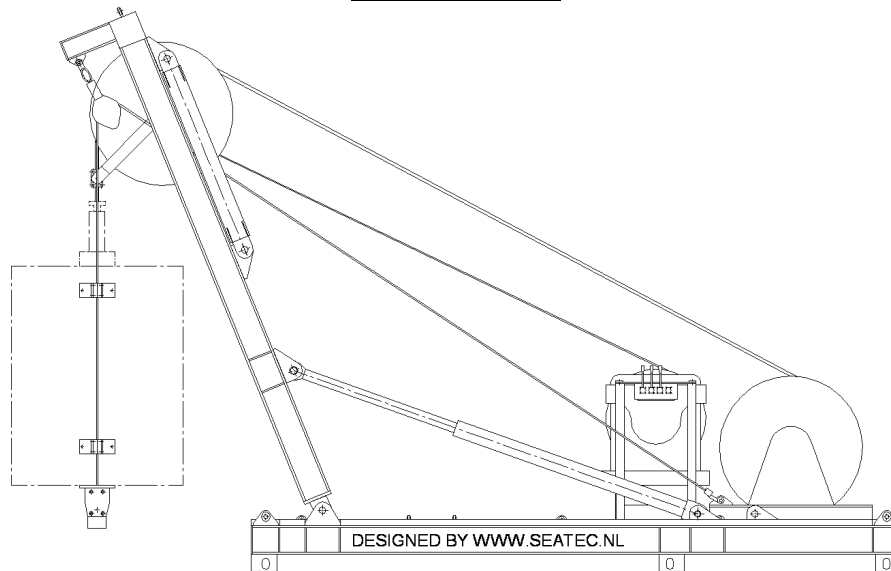

Transport position

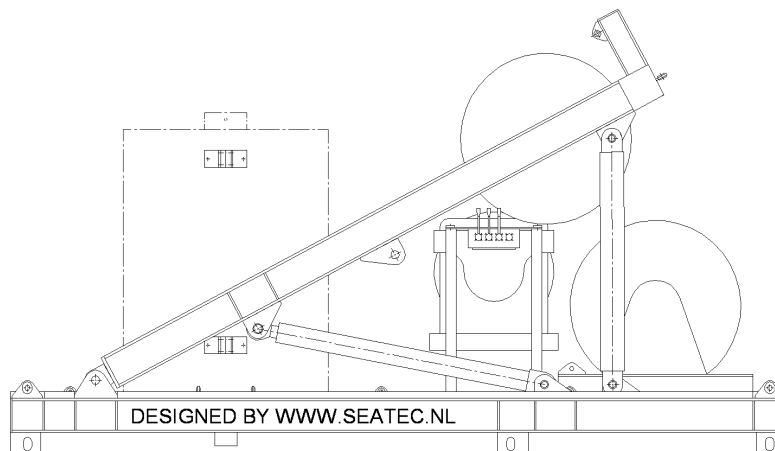

ORDER INFORMATION

For further information please contact us.

Information contained in this document is subject to change without prior notice