

LARS 20FT SWL 1500kg

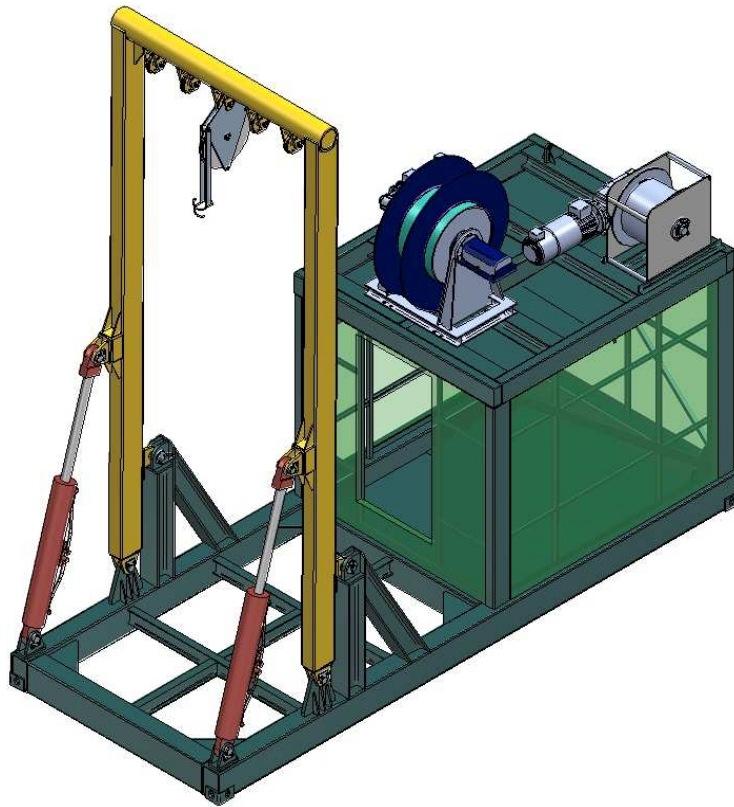

Product Highlights

- Designed to handle loads offshore up to Sea State 5.
- Lloyds approved design.
- Dimensions based on 20Ft container footprint.
- Winches placed on pedestal to create more working/storage space.

Information contained in this document is subject to change without prior notice

Specifications

Mechanical

- Tare weight (excl wires) 8.000 kg
- SWL (at sea state 5) 1.500 kg
- Dimensions LxWxH (mm) 6060x2445x3835 Boom height in vertical position 6120mm

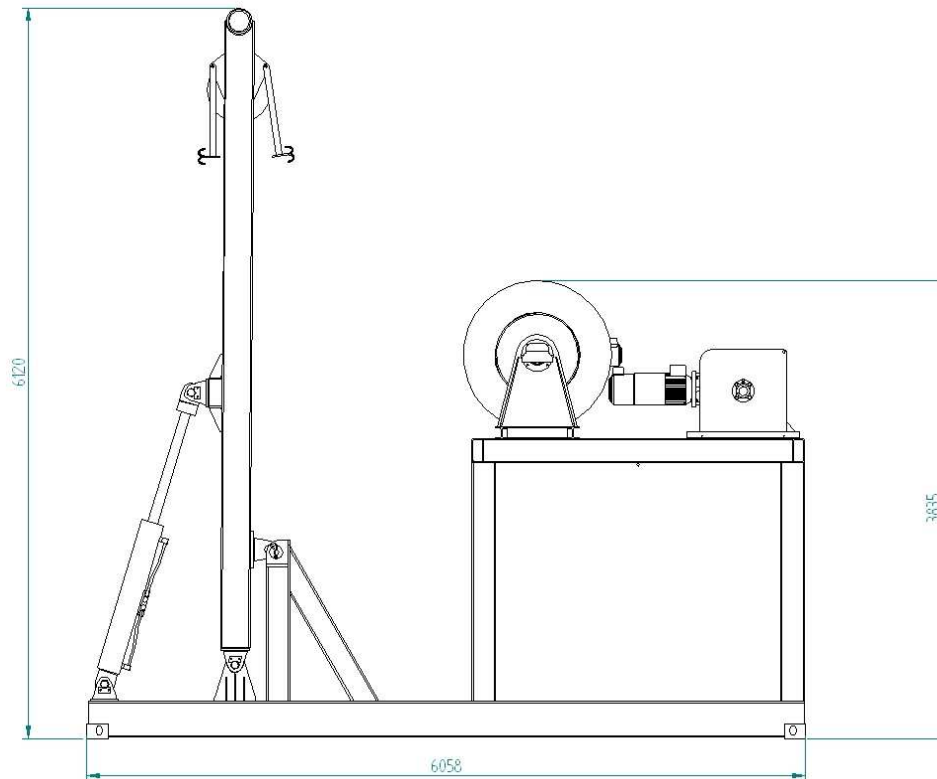

ORDER INFORMATION

For further information please contact us.

Information contained in this document is subject to change without prior notice