

## LARS 20FT SWL 1700kg



### Product Highlights

- Designed to handle loads offshore up to Sea State 5.
- Dimensions based on 20FT container footprint.
- Optional Lock Latch to improve recovery operation.
- Hydraulic driven winch.
- Lloyds approved design.

## Specifications

### Mechanical

- Tare weight (excl wires)	11 Ton
- SWL (at sea state 5)	1.7 Ton
- Dimensions LxWxH (mm)	6060x2445x2310mm
- Drum capacity (Ø32mm)	1100m
- (on customer request)	

### Hydraulic powerpack

Power (kW)	30 kW
Pressure	280 Bar
Flow	60 Liter/min

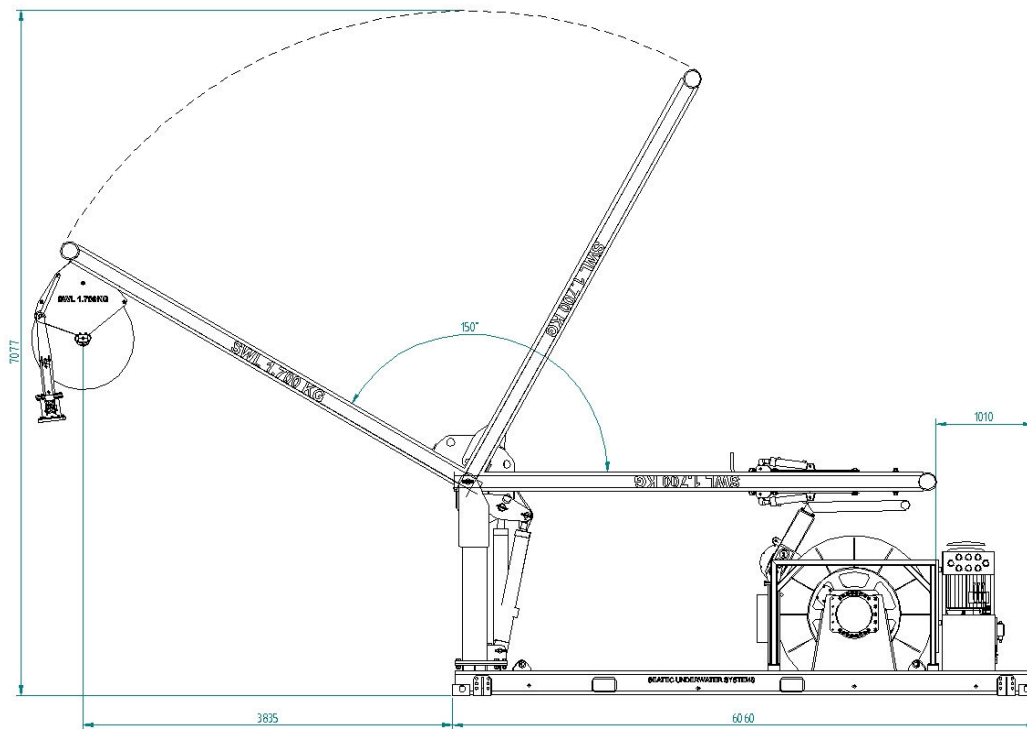

## ORDER INFORMATION

For further information please contact us.

*Information contained in this document is subject to change without prior notice*