

## COMP 014

Submersible compensator 15L

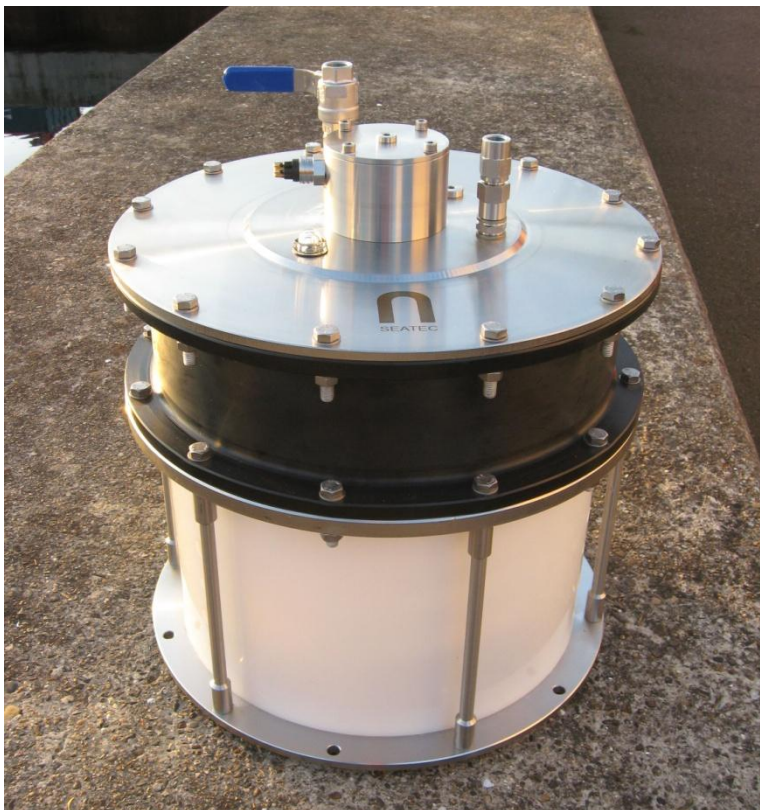

### Product highlights

- Designed for pressure compensation on hydraulic submersible systems.
- Corrosion resistant (AISI 316 L stainless steel and synthetics).
- Optionally provided with an analog level sensor or two level switches.
- 4-pole male underwater connector at level signalling versions.
- Oil indicator on top flange.
- Hydraulic connection on a hose socket (one standard, two on request).
- Compensation volume 15,0 litre.
- Other volumes available.
- Special electrical connection on request

N-Seatec Subsea Systems BV  
Industrieweg 29  
4301 RS Zierikzee  
P.O. Box 39  
4300 AA Zierikzee  
The Netherlands

t +31(0)111 456100  
f +31(0)111 456111  
e [info@n-seatec.com](mailto:info@n-seatec.com)  
[www.n-seatec.com](http://www.n-seatec.com)

Trade Register no 52686159  
Bank RABOBANK 119606992  
IBAN NL42RABO0119606992  
BIC RABO NL2U  
VAT NL8505.52.308.B.01

# PRODUCT INFORMATION SHEET

## Specifications

### Mechanical

- Dry weight empty 30 kg
- Compensation volume 15 l
- Pressure completely full 0,18 bar
- Pressure nearly empty 0,08 bar

### Electrical

- Supply voltage 12...27 VDC
- Output 4...20 mA

### Environmental

- Temperature range 0..+50 °C
- Rated waterdepth n.a.

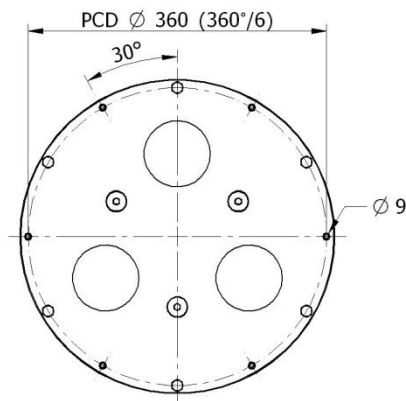
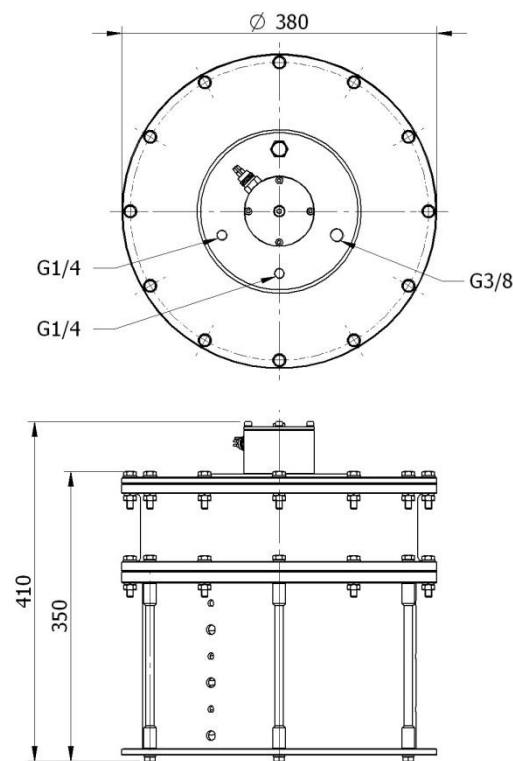

N-Seatec Subsea Systems BV  
Industrieweg 29  
4301 RS Zierikzee  
P.O. Box 39  
4300 AA Zierikzee  
The Netherlands

t +31(0)111 456100  
f +31(0)111 456111  
e info@n-seatec.com  
www.n-seatec.com

Trade Register no 52686159  
Bank RABOBANK 119606992  
IBAN NL42RABO0119606992  
BIC RABO NL2U  
VAT NL8505.52.308.B.01