

## COMP-002 Submersible Compensator 15L



### Product Highlights

- Designed for pressure compensation on hydraulic submersible systems.
- Dry or submerged use.
- No waterdepth rating.
- Corrosion resistant (AISI 316 L stainless steel and synthetics).
- Optionally provided with a one or a two level alarm indication.
- Subconn<sup>®</sup> 3-pole male standard circular underwater connector at alarm versions.
- Visual oil level by use of a perspex cylinder wall.
- Hydraulic connection on a hose socket (one standard, two on request).
- Compensation volume between 13 and 14 litre.
- Other volumes, light weight and heavy duty types available.

## Specifications

### Mechanical

- Dry weight empty                      Appr. 32 kg
- Subm. weight empty                    Appr. 25 kg

### Environmental

- Temperature range                    0..+50 °C
- Rated waterdepth                    none

### Electrical

- Normally Closed contact(s)
- | Standard | Type L | Type LL |
|----------|--------|---------|
| 0        | 1      | 2       |

### Connections

- Pin 1    Supply
- Pin 2    LOW NC contact
- Pin 3    LOW-LOW NC contact

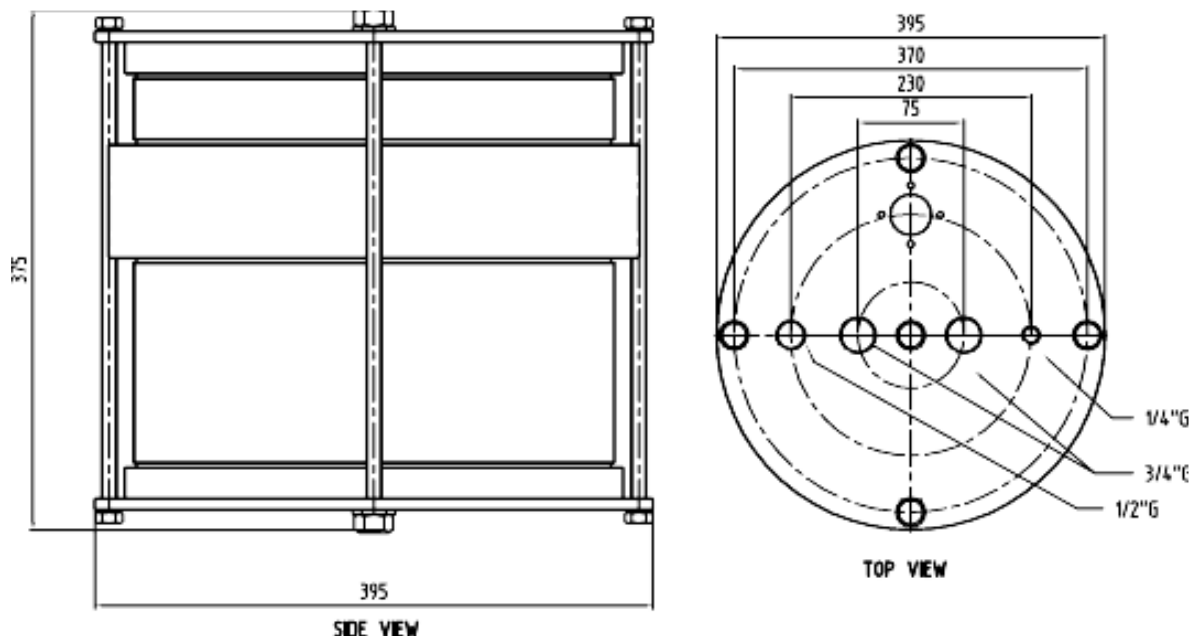

## Order information

Product type	Configuration
COMP-002-STANDARD	Standard compensator excl. level signalling
COMP-002-SWITCH	Standard compensator incl. 2 level switches
COMP-002-LEVEL	Standard compensator incl. analog level signalling

When hose sockets are required, please specify at order.