

COMP-009 Submersible Compensator 2L



Product Highlights

- Designed for pressure compensation on hydraulic submersible systems.
- No waterdepth rating.
- Corrosion resistant (AISI 316 L stainless steel and synthetics).
- Optionally provided with an analog level sensor or two level switches.
- 4-pole male standard circular underwater connector at level signalling versions.
- Oil indicator on top flange .
- Hydraulic connection on a hose socket (one standard, two on request).
- Compensation volume 2,0 litre.
- Other volumes available.
- Special electrical connection on request

Information contained in this document is subject to change without prior notice

Specifications

Mechanical

- Dry weight empty 11 kg
- Compensation volume 2 l

Environmental

- Temperature range 0..+50 °C
- Rated waterdepth none

Electrical

- Supply voltage -
- Output 2 x NC contact

SWITCH type

-
- 2 x NC contact

LEVEL type

- 12...27 VDC
- 4...20 mA

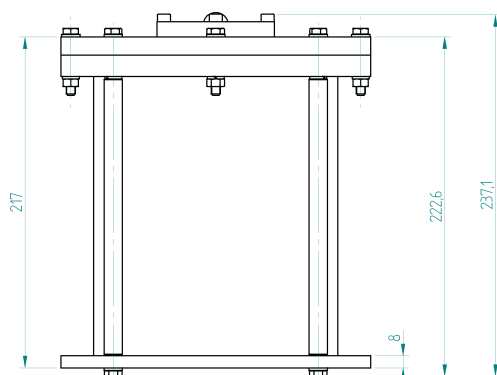
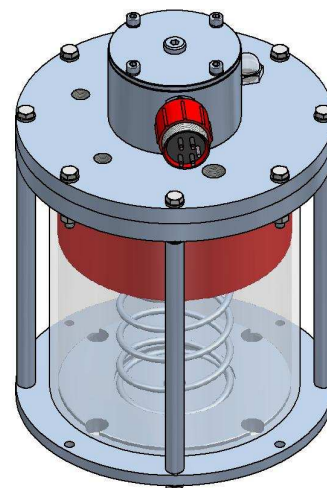
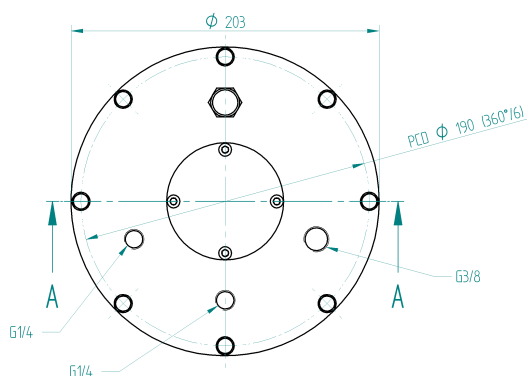

STANDARD VERSION

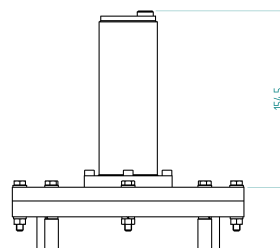

SWITCH VERSION

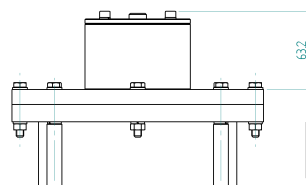

LEVEL VERSION

Order information

Product type	Configuration
COMP-009-STANDARD	Standard compensator excl. level signalling
COMP-009-SWITCH	Standard compensator incl. 2 level switches
COMP-009-LEVEL	Standard compensator incl. analog level signalling

When hose sockets or protective pressure valves are required, please specify at order!

Information contained in this document is subject to change without prior notice